

*Quality without  
compromise*



*Our experience  
at your service*



**FACCIN USA INC.**

907 U.S. HWY 301 S. - TAMPA, FLORIDA 33619 U.S.A.

Phone (001) 813-664-8884 - Fax (001) 813-664-4544

e-mail: [info@faccin.com](mailto:info@faccin.com) - Web site: [www.faccin.com](http://www.faccin.com)

**PLATE BENDING ROLLS**



**FACCIN**

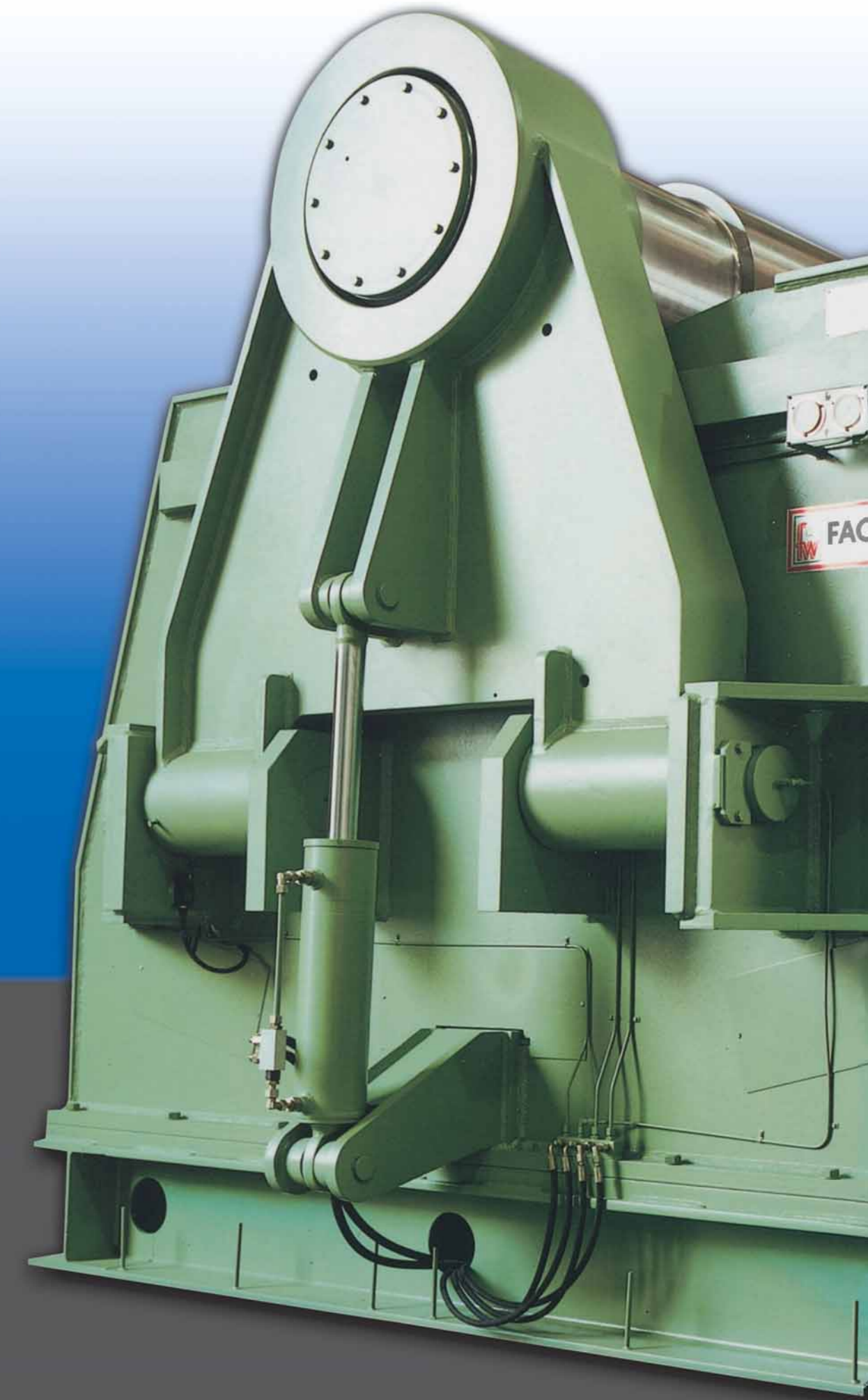

**RGS** Linear slide system  
for roll positioning

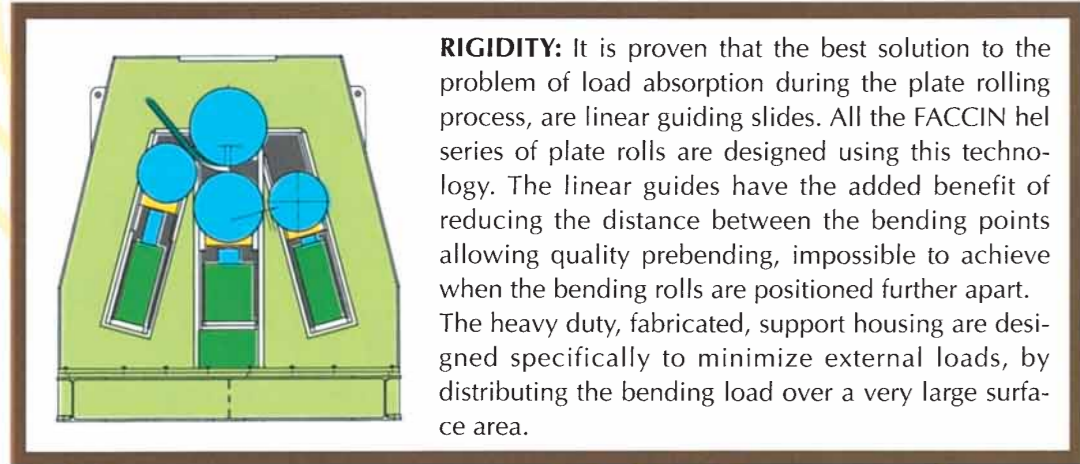

**MGS** Double bearing system  
for roll parallelism

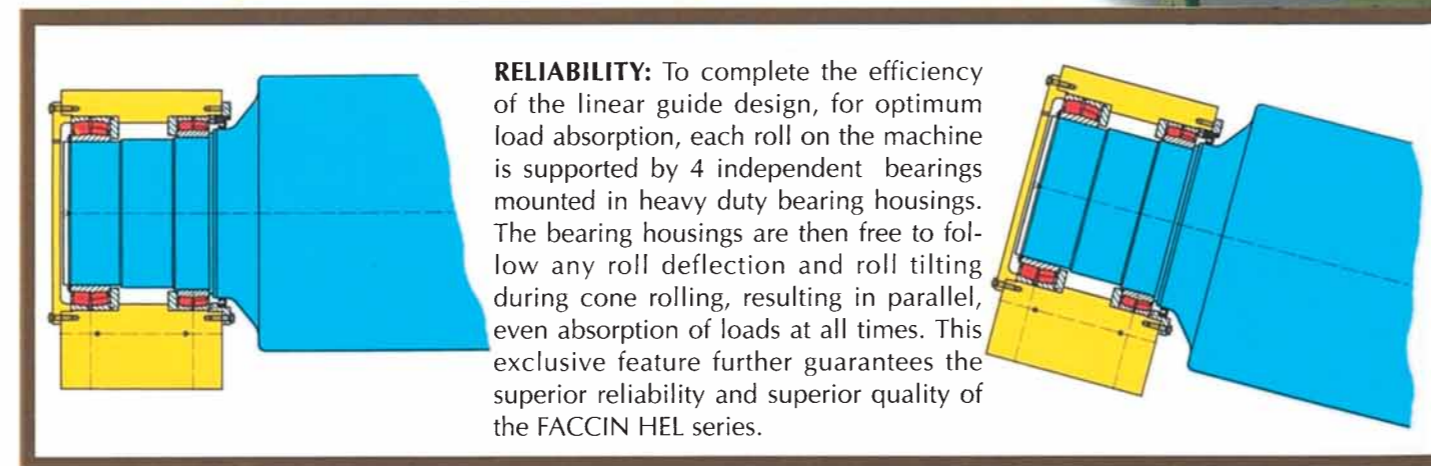

**EPS** Electronic balancing system  
for roll parallelism

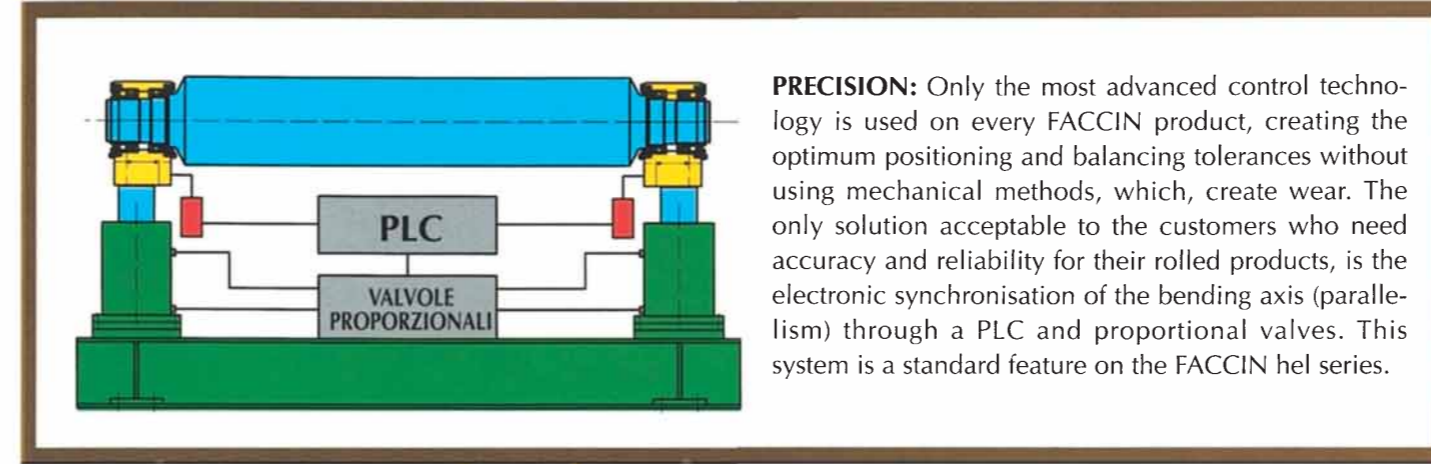

**PGS 2000** Computer numerical  
controls

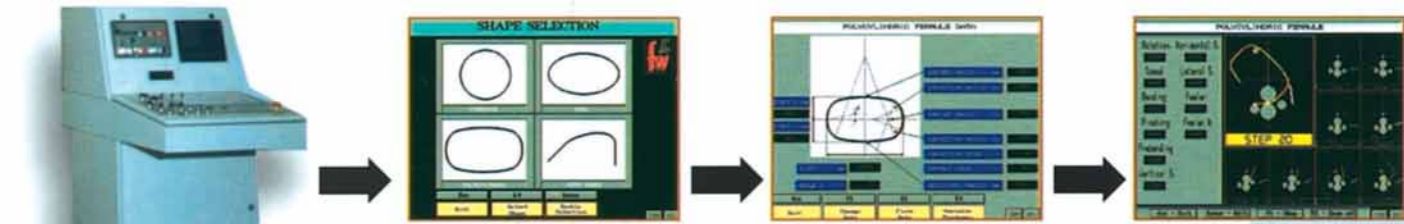

**PRODUCTIVITY:** Fast movement and maximum torque at high speed is guaranteed by installing high power motors and energy saving planetary gearboxes, independently mounted on each driven roll. A wide range of handling equipment and numerical controls are available on request, allowing the FACCIN HEL to offer state of the art rolling solutions. It is simple and fast to both create new programs and manage data base files with a Windows interface. The PGS 2000 is widely recognized as the most advanced and powerful computer numerical control system available on the bending roll market today.

