

# Profile bending: Easy way or Hard way?

Please sign with a X the profile you'd like to bend and specify the maximum size.

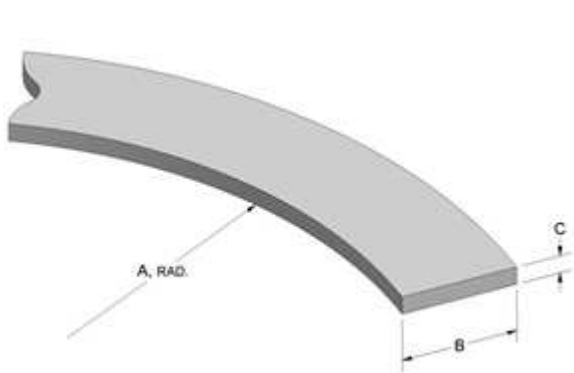

**Flat Bar rolled the hard way.**

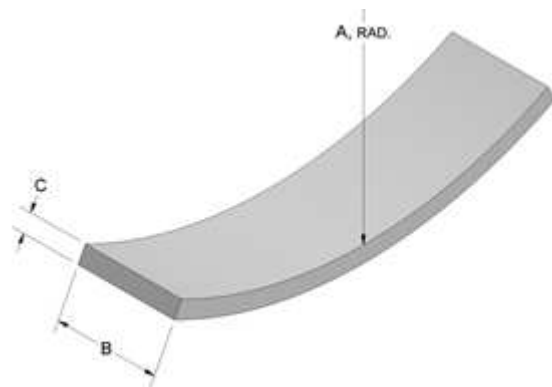

**Flat bar rolled the easy way.**

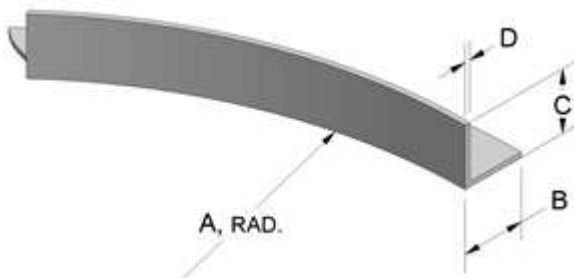

**Angle rolled leg out.**

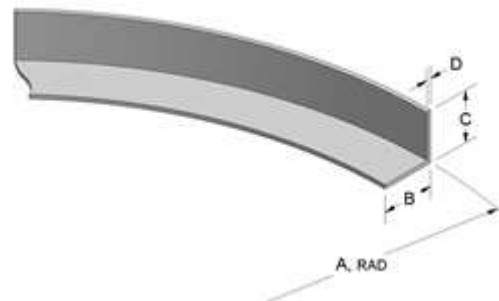

**Angle rolled leg in.**

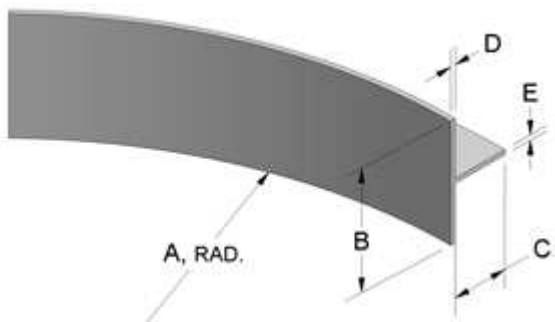

**Structural T rolled leg out.**

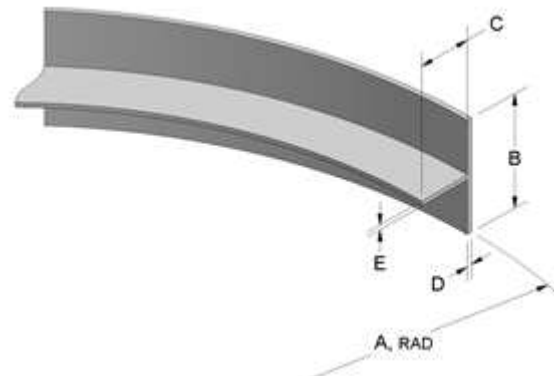

**Structural T rolled leg in.**

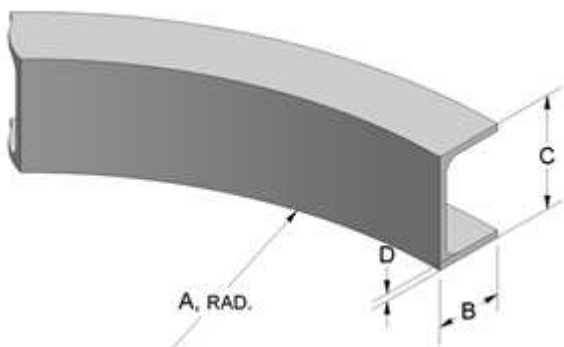

**Structural Channel rolled leg out.**

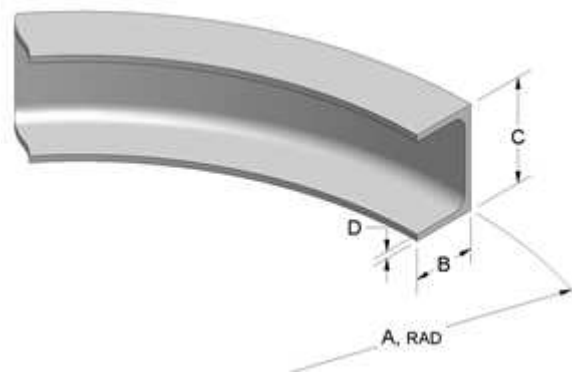

**Structural Channel rolled leg in.**

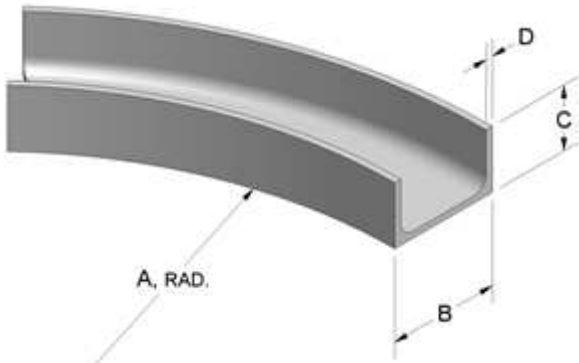

**Structural Channel rolled the hard way.**

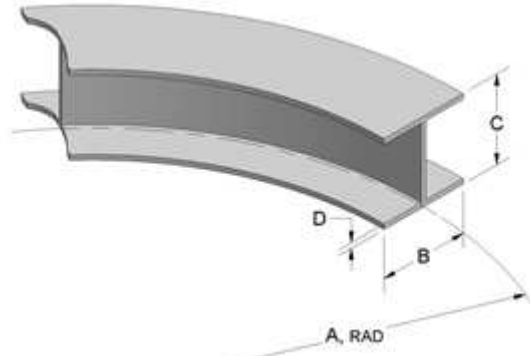

**Wide flange beam rolled the easy way.**

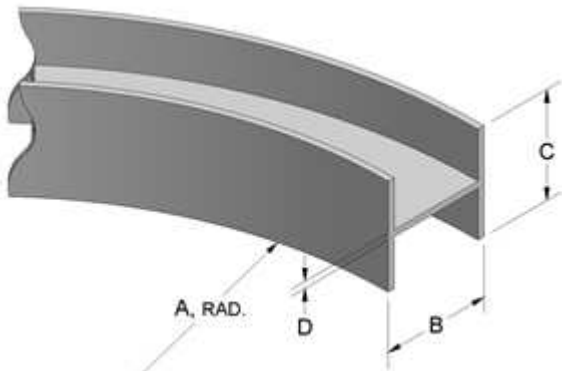

**Wide flange beam rolled the hard way.**



**Round bar (A is the centerline radius).**

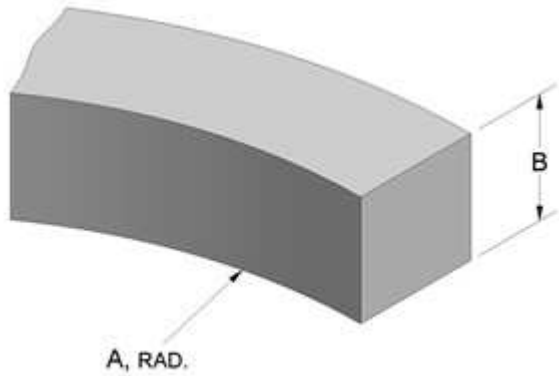

**Rolled square stock.**

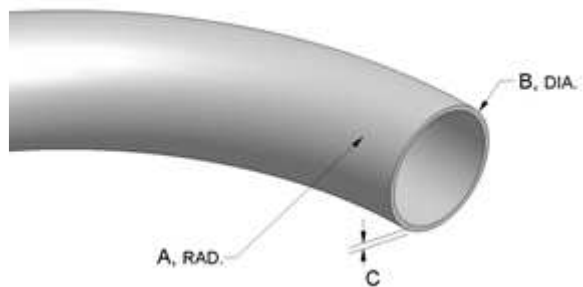

**Rolled pipe (A is the centerline radius).**